

Grooved Resilient OS&Y Gate Valve (XZ81X), UL/FM Approved

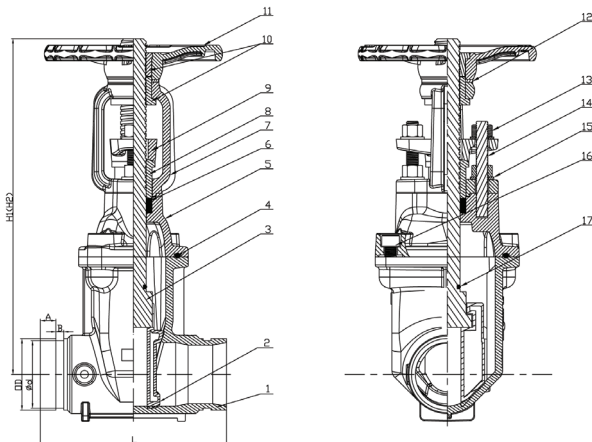

XZ81X

- Connection Ends: Groove to AWWA C606
- Working Pressure: 300PSI
200PSI and 250PSI available upon request
- Temperature Range: 0°C- 80°C
- Coating: Fusion Bonded Epoxy Coating in accordance with ANSI/AWWA C550 or painting upon request



MATERIAL SPECIFICATION

Part No.	Part	Standard Specification	Options
1	Valve Body	ASTM A536, 65-45-12	
2	Resilient Wedge Disc	ASTM A536, 65-45-12+EPDM	
3	Stem	AISI 420	AISI 304, AISI 316, AISI 431, Al-bronze
4	Bonnet Gasket	EPDM	NBR
5	Bonnet	ASTM A536, 65-45-12	
6	Washer	Brass HPb59-1	
7	Yoke	ASTM A536, 65-45-12	
8	Stem Bushing	Brass HPb59-1	
9	Gland	ASTM A536, 65-45-12	
10	Stem Nut	Brass HPb59-1	Bronze ZQSn5-5-5
11	Handwheel	ASTM A536, 65-45-12	Pressed Steel
12	Washer	Brass HPb59-1	
13	Gland Nut	Carbon Steel Zinc Plated	AISI 304, AISI 316
14	Stud	Carbon Steel Zinc Plated	AISI 304, AISI 316
15	Flat Washer	Carbon Steel Zinc Plated	AISI 304, AISI 316
16	Nut	Carbon Steel Zinc Plated	AISI 304, AISI 316
17	O-Ring	EPDM	NBR

Note: For special material request other than standard specification, please indicate clearly on the inquiry or order list.

DN		Dimensions(mm)						
Inch	mm	L	H1(Close)	H2(Open)	OD	d	A	B
2"	50	178	348	400	60.3	57.15	15.88	7.92
2.5"	65	190	373	440	73	69.09	15.88	7.92
3"	80	203	408	490	88.9	84.94	15.88	7.92
4"	100	229	471	573	114.3	110.08	15.88	9.52
5"	125	254	541	665	141.3	137.03	15.88	9.52
6"	150	267	601	755	168.3	163.96	15.88	9.52
8"	200	292	774	975	219.1	214.4	19.05	11.13
10"	250	330	1029	1283	273	268.28	19.05	12.7
12"	300	356	1065	1370	323.9	318.29	19.05	12.7