

Flanged Resilient NRS Gate Valve (Z45XC), UL/FM Approved

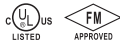

Z45XC



- Connection Ends: Flange to ASME B16.1 CL 125
- Working Pressure: 300PSI
200PSI and 250PSI available upon request
- Temperature Range: 0°C - 80°C
- Coating: Fusion Bonded Epoxy Coating in accordance with ANSI/AWWA C550



Z45X

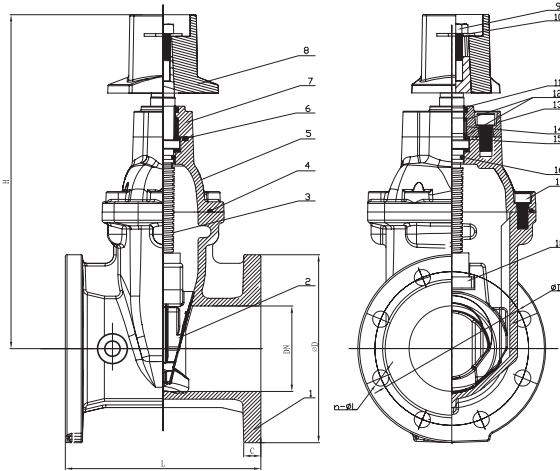

MATERIAL SPECIFICATION

Part No.	Part	Standard Specification	Options
1	Valve Body	ASTM A536, 65-45-12	
2	Resilient Wedge Disc	ASTM A536, 65-45-12+EPDM	
3	Stem	AISI 431	AISI 304, AISI 316, AISI 420, Al-bronze
4	Bonnet Gasket	EPDM	NBR
5	Bonnet	ASTM A536, 65-45-12	
6	O-Ring	NBR	EPDM
7	Gland	ASTM A536, 65-45-12	
8	Stem Cap	ASTM A536, 65-45-12	
9	Bolt	Carbon Steel Zinc Plated	AISI 304, AISI 316
10	Flat Washer	Carbon Steel Zinc Plated	AISI 304, AISI 316
11	Ring Wiper	EPDM	NBR
12	O-Ring	NBR	EPDM
13	Nut	Carbon Steel Zinc Plated	AISI 304, AISI 316
14	Axis Guide	Brass HPb59-1	
15	Washer	Brass HPb59-1	
16	O-Ring	NBR	EPDM
17	Nut	Carbon Steel Zinc Plated	AISI 304, AISI 316
18	Wedge Nut	Brass HPb59-1	Bronze ZQSn5-5-5

Note: For special material request other than standard specification, please indicate clearly on the inquiry or order list.
Size 2"-5" with 1pc of 1/2" bronze NPT tapping plug, size 6"-12" with 1pc of 3/4" bronze NPT tapping plug.

DN		Dimensions(mm)						
Inch	mm	L	H(Z45X)	H(Z45XC)	D	D1	C	n-ΦL
2"	50	178	254	278	152	120.7	16	4-Φ19.1
2.5"	65	190	275	300	178	139.7	17.5	4-Φ19.1
3"	80	203	301	321	191	152.4	19.1	4-Φ19.1
4"	100	229	355	375	229	190.5	19.1	8-Φ19.1
5"	125	254	393	415	254	215.9	19.1	8-Φ22.2
6"	150	267	448	455	279	241.3	19.1	8-Φ22.2
8"	200	292	548	565	343	298.5	22.2	8-Φ22.2
10"	250	330	626	636	406	362	23.8	12-Φ25.4
12"	300	356	722	731	483	431.8	25.4	12-Φ25.4